

**NOTES:**

1. ALL WATER SERVICE COMPONENTS SHALL BE IRON PIPE SIZE. NO GALVANIZED PIPE OR FITTINGS SHALL BE USED. WATER SERVICE SADDLE, CORPORATION STOP, AND PIPE SHALL BE SIZED AS FOLLOWS:
  - A. SINGLE SERVICE: 1".
2. METER BOX LOCATIONS SHALL BE SHOWN ON WATER SYSTEM PLANS AND APPROVED BY THE DEPARTMENT OF PUBLIC WORKS. METER BOX LOCATION GENERALLY WILL BE LOCATED ON THE HOMEOWNER PROPERTY AS FOLLOWS:
  - A. SINGLE SERVICE: THIRTY (30") FROM R.O.W. CENTERED ON COMMON PROPERTY LINE.
3. SERVICE PIPE SHALL BE CLASS 200, SIDR 7 POLYETHYLENE PRESSURE PIPE CONFORMING TO AWWA C901.
4. FORD STAINLESS STEEL INSERT (STIFFENER) TO BE USED WITH POLYETHYLENE PRESSURE PIPE AT FITTINGS PER MANUFACTURERS RECOMMENDATIONS.
5. SERVICE LINES SHALL BE INSTALLED WITH A MINIMUM COVER OF SIX (6') FEET AND SHALL RISE TO FOUR (4') FEET, WITHIN A MAXIMUM DISTANCE OF EIGHTEEN (18") INCHES OF METER BOX.
6. SERVICE CONNECTIONS SHALL BE THIRTY-SIX (36") INCHES FROM FITTINGS OR WATER MAIN PIPE ENDS. MULTIPLE SERVICE CONNECTIONS IN THE SAME JOINT OF PIPE SHALL BE SEPARATED BY TWENTY-FOUR (24") INCHES AND NOT IN THE SAME HORIZONTAL LEVEL. -ABSOLUTE-
7. SERVICE PIPE SHALL BE FLUSHED IMMEDIATELY PRIOR TO METER INSTALLATION.
8. WATER METERS SHALL BE 3/4" OR 1" SENSUS SR11 EQUIPPED WITH A WATERPROOF ELECTRONIC COMMUNICATIONS REGISTER (TRPL EPX MTR) LESS TOUCHPAD READING IN 1,000 GAL. W/ 20' OF WIRE. FOR 3/4" METERS, USE FORD PART #A44-NL (2 EA.). A METER TRANSCIEVER UNIT (520M MXU DUAL PORT) WITH EACH METER. THE MXU SHALL BE MOUNTED ON A 1/2" DIAMETER CONDUIT EMBEDDED INTO THE GROUND. THE MXU SHALL BE POSITIONED 12 INCHES MAXIMUM BELOW THE METER LID. DEVELOPERS/CONTRACTORS SHALL SUPPLY THE DEPT. OF PUBLIC WORKS WITH THE WATER METER ASSEMBLY TO INSTALL UNLESS OTHERWISE DIRECTED.
9. MAINTAIN SEPARATION DISTANCES IN ACCORDANCE WITH IDAPA 58.01.08.
10. REFER TO CITY OF McCall STANDARD REVISIONS TO ISPWC AND CONDITIONS SECTION 404 FOR REQUIREMENTS ON CONNECTIONS TO THE PRIVATE SIDE OF THE WATER METER.

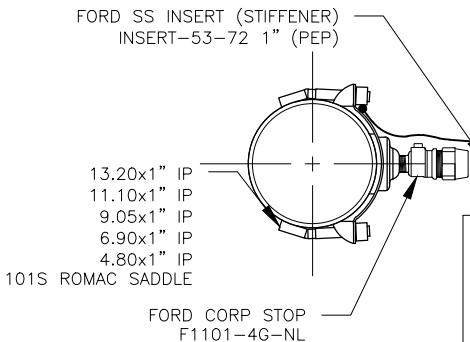
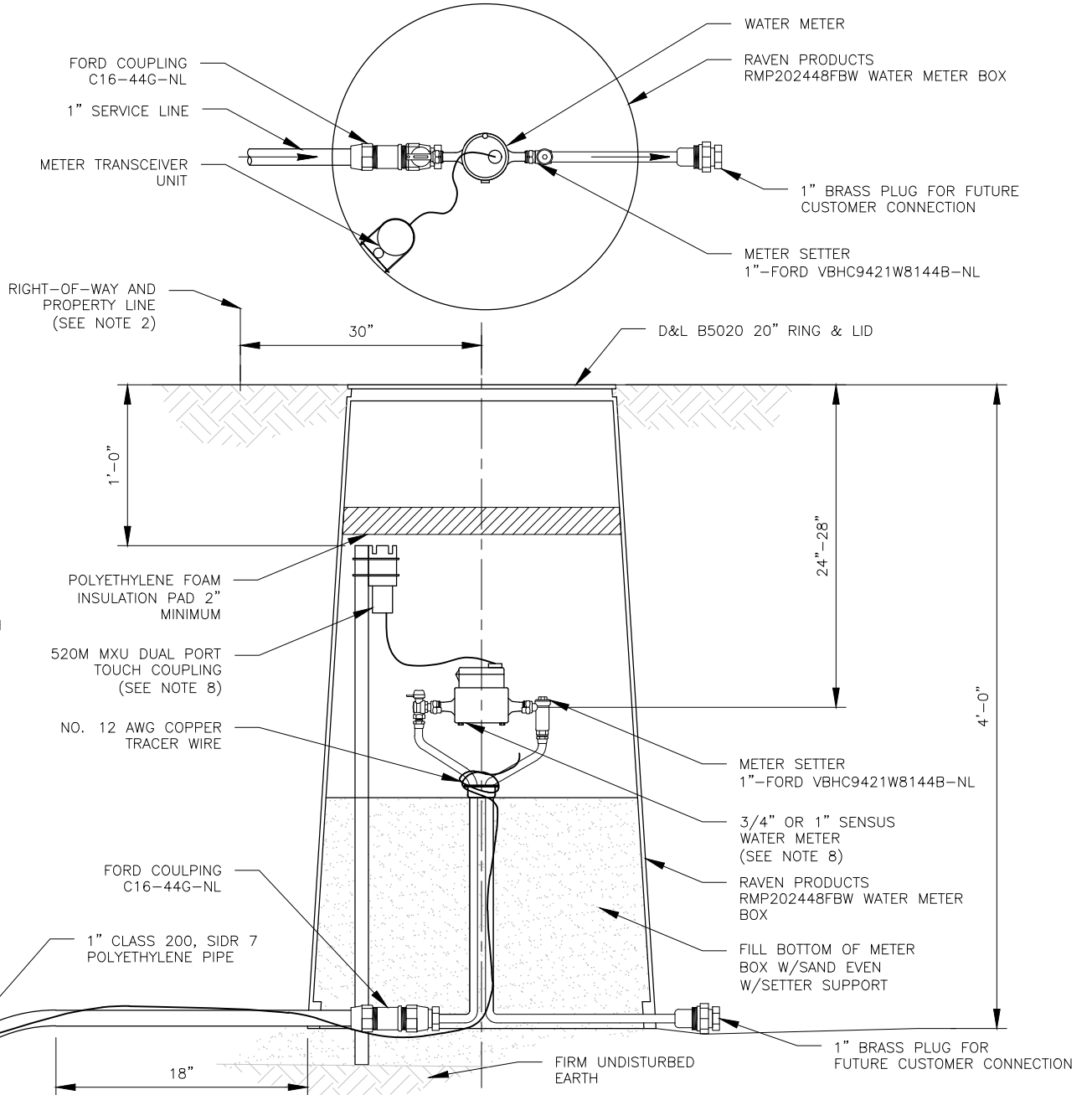

**PUBLIC WORKS DEPARTMENT**  
815 N. SAMSON TRAIL  
McCall, IDAHO 83638  
208.634.5580

CITY OF McCall		
SINGLE WATER SERVICE CONNECTION - 3/4" OR 1"		
PROJECT	DRAWN BY	SHEET NO.
DATE	1/26/2022	1 OF 1

STANDARD DRAWING NO.  
**MSD-401B**